

AETES

HV 3000VA MANUAL

1. INTRODUCTION

This series is a compact and fully pure sinewave line interactive UPS, and it designs for critical application and environment, such as desktops, servers, workstations, and other networking equipments.

This model is available in the output ratings 3000VA. This series protects your sensitive electronic equipments against power problems including power sags, spike, brownouts, line noise, and blackouts.

This series designs from two-in-one form factor; it can be placed either in Rack 2U or Tower. The front panel of the UPS includes LED indicators and four push buttons (Power Switch, UPS Test/Silence, Configure, and Enter) that allow to monitor easily, configuration and control, AC line-in, notification of site wiring fault and output load status of the UPS. It also includes four LED bar graphic (Load/Battery Level Indication); two status indications (On AC, On Battery); five alarm indications (Overload, Over Temperature, Site Wiring Fault, Battery Fault, Self Test Failure). A push button from the front panel allows silencing of the AC fail alarm and the initiation of the UPS self test sequence as well.

This series is powered from the AC mains and supply AC outputs via receptacles on the rear panel. Communication and control to the unit is available through serial or USB ports located on the rear panel. The serial port will support communications directly with a server. The communications protocol for the serial ports shall conform to true RS232 interface.

Features:

- Microprocessor control guarantees high reliability
- High frequency design
- Built-in boost and buck AVR
- User replaceable design
- Selectable output range and line sensitive
- Cold startup capability
- Built-in Dry contact/RS-232/USB communication port
- SNMP allows for web-based remote or monitoring management
- Enable to extend runtime with scalable external battery pack
- Overload, Short-circuit, and overheat protection
- 19" rack mount available for all models

2. SAFETY INSTRUCTION – CAUTION

IMPORTANT SAFETY INSTRUCTIONS

SAVE THESE INSTRUCTIONS - This Manual Contains Important Instructions that should be Followed during Installation and Maintenance of the UPS and Batteries.

WARNING: Do not attempt to repair and service this UPS. This UPS contains high voltages which could cause the risk of electrical shock. Even this UPS is disconnected from the electrical outlet, the dangerous voltage still may be present through the battery. All maintenance and battery replacement should be performed by qualified service personnel only.

1. This UPS should be placed indoors with adequate airflow and free of contamination. To install or operate it in a clean and indoor environment, free from moisture, flammable liquids, and direct sunlight. Ambient temperature range must be 0°C to 40°C (32°F to 104°F).
2. This UPS is designed for Commercial/Industrial use only. It is not intended for use with life support application and other designated “life-critical” devices.
3. Do not remove the input power cord when this UPS is turned on. This removes the safety ground from this UPS and the equipment connected to the UPS.
4. Turn off this UPS and disconnect input power cord before battery replacement.
5. Battery contains high short-circuit current. Replacing or servicing the battery which should be performed and supervised by qualified service personnel knowledgeable of batteries and required precautions.
 - Remove watches and jewelries
 - Use tools with insulated handles
 - Wear rubber gloves and boots.
 - Do not lay tools or metal parts on top of batteries.
 - Disconnect charging source prior to connecting or disconnecting

battery terminals.

6. When replacing the batteries, use the appropriate replacement battery kits, same number and type of battery are MUST.
7. Do not open or mutilate the battery. Released electrolyte is harmful to skin and eyes that may be toxic.
8. Do not dispose of battery in a fire. Battery may explode. Proper disposal of battery is required. Please refer to your local laws and regulations for disposal requirements.
9. To reduce the risk of fire, use only No. 26 AWG or larger telecommunication line cord.





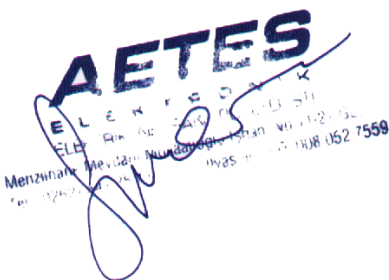

2. SAFETY INSTRUCTION – CAUTION

10. This UPS contains high voltages which may cause the risk of electric shock. Do not remove cover. There are no user replaceable parts inside this UPS. Please contact your local dealer or distributor for service.
11. To reduce the risk of fire, connect to a circuit provided with 1.25(at least 20A) amperes maximum branch circuit over-current protection in accordance with the National Electric Code, ANSI/NFPA.
12. This pluggable type A equipment with battery already installed by the supplier is operator installable and may be operated by laymen.
13. During the installation of this equipment it should be assured that the sum of the leakage currents of the UPS and the connected loads does not exceed 3.5mA.
14. Attention, hazardous through electric shock. Also with disconnection of this unit from the mains, hazardous voltage still may be accessible through supply from battery. The battery supply should be therefore disconnected in the plus and minus pole of the battery when maintenance or service work inside the UPS is necessary.
15. The mains socket outlet that supplies the UPS shall be installed near the UPS and shall be easily accessible.



2. SAFETY INSTRUCTION – CAUTION

2.1 Description of Commonly Used Symbols

Symbol & Description	
Symbol	Description
	Alert you to pay special attention
	Caution of high voltage
	Alternating current source(AC)
	Direct current source(DC)
	Protective ground
	Recycle
	Keep UPS in a clear area

AETES
ELEKTRONIK
Metzstraße 10, 41523 Grefrath, NRW
Tel: +49 2124 7559

3. SYSTEM DESCRIPTION

Front Panel —

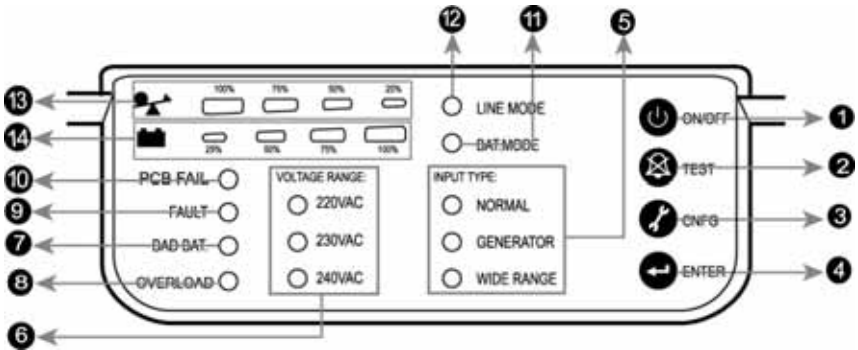

No.	Function	Description
1	Switch	ON/OFF
2	Switch	Self-Test/ Alarm Silence
3	Switch	Config
4	Switch	Enter
5	LED	Input Type(Operating Mode)
6	LED	Voltage Range
7	LED	Bad Battery
8	LED	Overload
9	LED	Fault
10	LED	PCB Fail (or Site Fault)
11	LED	Battery Mode
12	LED	Line Mode
13	LED	Capacity of Load
14	LED	Capacity of Battery

3. SYSTEM DESCRIPTION

1. Power Switch:

- To turn on the UPS, press the  button more than three seconds
- To turn off the UPS, press and hold this button until you hear the UPS beep ceases.

2. UPS Test/ Alarm Silence:

- The battery is fully charged during in line mode. To perform self-test function, press and hold the  button for five seconds.
- To disable alarm buzzer, press this button for a second that will turn off the alarm buzzer. Each time a new alarm event is encountered the alarm that will sound and press this button to turn off the alarm.

Note: Unable to disable alarm buzzer as below conditions: Low Battery, Overload, Fan Failed, Fan Fault Time Out, Over Temperature.

3. Configure:

To reconfigure the internal UPS setup options, follow the procedure as below:

Step 1: Press the Configure  button more than three seconds. Then UPS will transfer from configure mode to “output voltage mode”.

Step2: Press the Configure  button more than one second, the UPS allows you to select the “output voltage mode” one by one.

Step3: After selecting the mode, press the Enter  button more than three seconds, the “output voltage mode” is configured.

Step4: UPS will automatically transfer from configure mode to “operating mode”.

Step5: Press the Configure  button more than one second; the UPS will allow you to select the “operating mode” one by one.

Step6: After selecting the mode, press the  button more than three seconds, the “operating mode” is configured.

4. Enter:

Press the  button after you choose the mode.

3. SYSTEM DESCRIPTION

5. Input Type (Operating Mode) LED:

INPUT TYPE:

- NORMAL
- GENERATOR
- WIDE RANGE

- Normal mode: The Yellow LED indicator will illuminate during normal mode, the UPS accepts AC input voltage range from +/-20%.
- Generator: No change to voltage window. However, the low frequency transfer point is changed to 40Hz and there is no limitation for high frequency transfer point.
- Wide range: The LED indicator will illuminate, the UPS accepts AC input voltage range from -30% ~ +20%.

6. Voltage Range (Output Voltage Mode) LED:

UPS Output voltages selection: 110VAC/120VAC/127VAC or 220VAC/230VAC/240VAC.

VOLTAGE RANGE:

- 110VAC
- 120VAC
- 127VAC

VOLTAGE RANGE:

- 220VAC
- 230VAC
- 240VAC

7. Bad Battery LED:

The LED indicator will light on when the battery is failed or if the battery is disconnected, LED will flash every two seconds. Please check your battery connection; replace the battery or contact your local dealer for a battery replacement kit.

8. Overload LED:

The LED indicator will light on when the UPS overload timeout.

9. Fault LED:

The LED indicator will light on when the UPS fails/overload is timeout /or short-output.

3. SYSTEM DESCRIPTION

10. PSDR FAIL LED(or SITE FAULT LED):

- PSDR FAIL LED: the LED indicator will light on when the power module of UPS fails.
- SITE FAULT LED: the LED indicator will light on when UPS is plugged into an improperly utility

Note: "SITE FAULT" function is only available for 120Vac models.

11. BAT Mode LED (Battery Mode):

The LED indicator will flash every five seconds when the UPS is providing battery power to your equipment. On the other hand, the LED indicator gives you a warning which will flash every two seconds when the battery is low.

12. Line Mode LED:

The line LED indicator illuminates when the AC source is present.

13. Capacity of Load LED:

- **Load Indicator:** The  LED indicator and the load level indicator will illuminate to show the load level.
- **Load Level Indicator:**



There are four LED bar graphic to indicate the percentage of UPS load capacity which is being used by the protected equipment. The greater the load, the more LED indicators that will be illuminated. Each LED indicator designates a 25% of the UPS output capacity. Please see the following load level respectively.

- ◆ 0 ~ 25%: 1st LED indicator
- ◆ 26% ~ 50%: 1st and 2nd LEDs indicator
- ◆ 51% ~ 75% : 1st, 2nd, and 3rd LEDs indicator
- ◆ 76% ~ 100%: All of four LED indicators will illuminate

14. Capacity of Battery LED:

- **Battery Indicator:** The  LED indicator and battery level indicator will illuminate to show battery level.

3. SYSTEM DESCRIPTION

- **Battery Level Indicator:**



There are four LED bar graphic to indicate the amount of battery capacity remaining. The higher the battery capacity, the more LED indicators that will be illuminated. Each LED indicator designates a 25% capacity level. Please see the following capacity level respectively.

- ◆ 0 ~ 25%: 4th LED indicator
- ◆ 26% ~ 50%: 3rd and 4th LEDs indicator
- ◆ 51% ~ 75%: 2nd, 3rd, and 4th LEDs indicator
- ◆ 76% ~ 100%: All of four LED indicators will illuminate

Indicator Condition —

Condition	Alarm
Utility Mode (AC Mode)	Line LED Lighting
Backup Mode (Power Failure)	Flashing every four seconds
Site Fault	Site fault LED lighting (For 120VAC Models) 4 segment LED bar: 0~25%: 4 th LED lighting; 26~50%: 3 rd and 4 th LEDs lighting; 51~75%: 2 nd , 3 rd , and 4 th LEDs lighting; 76~100%: all of 4 LEDs lighting
UPS Fault	Fault LED lighting
Overload	Overload LED lighting
Low Battery	Battery LED flashing every second

Audible Alarm Condition —

Condition	Alarm
Backup Mode (Power Failure)	Sounding every four seconds
Low Battery	Sounding every second
UPS Fault	Continuously Sounding
Overload	Sounding every second
Battery Replacement	Sounding every second

3. SYSTEM DESCRIPTION

HV 3000VA

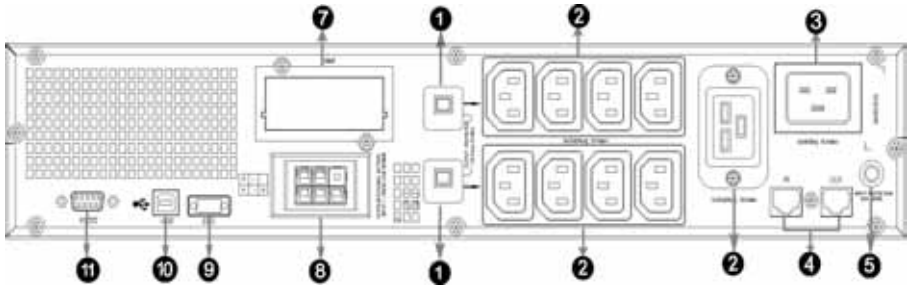

Rear panel for HV model

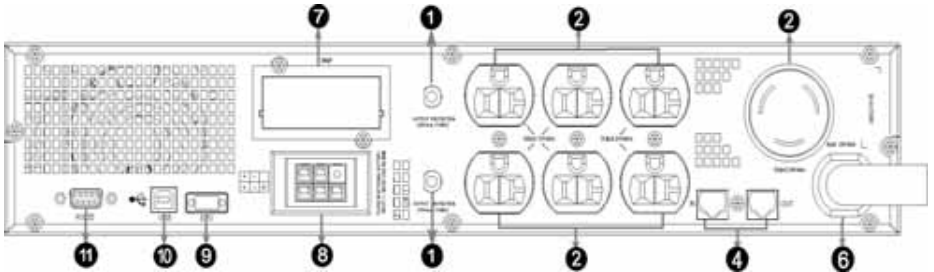

Rear panel for LV model

AETES
ELEKTRONIK
Menzhirat, Medan, Sumatera Utara
Telp. (061) 412 7559

3. SYSTEM DESCRIPTION

Rear panel description for LV and HV models table

No.	Function	
	LV model (110/120/127Vac)	HV model (220/230/240Vac)
1	Output Breaker	
2	AC Output	
3	AC Input	
4	Modem/Network Surge Protection	Modem/Network Surge Protection
5	Input Breaker	N/A
6	Input Power Cord	N/A
7	SNMP Slot	SNMP Slot
8	External Battery Connector	External Battery Connector
9	EPO	EPO
10	USB Port	USB Port
11	RS232 / Dry-Contact Communication Port	

AETES
ELEKTRONIK
Merzhanik, Mevdan, Nurdanbek, Shan, NUR US 7559
Tel: 02422 222 222

4. INSTALLATION

1. Inspecting the Equipment

Inspect the UPS upon receipt. If the UPS has been damaged during shipment, keep the box and packing material for the carrier. Notify the carrier and dealer immediately.

2. Placement

This UPS should be installed indoors with adequate airflow and free of contamination. Locate it in a clean and indoor environment, free from moisture, flammable liquids, and direct sunlight. Maintain a minimum clearance of 4 inches (100mm); an ambient temperature range must be 0°C to 40°C (32°F to 104°F), and operating humidity range must be 20% to 80% relative humidity (non-condensing).

CAUTION: The long term uses at ambient temperature in higher than 25°C which should reduce battery life. In addition, place the UPS unit away from the monitor at least 20cm to avoid interference.

3. Charging

This UPS is shipped from the factory with its internal battery fully charged; however, some charge may be lost during shipping. The battery should be recharged prior to use. Plug the UPS into an appropriate power supply and allow the UPS to charge at least 4 hours.

4. Load Connection

Connect one load-related device to each of the power receptacles supplied at the rear of the UPS.

5. Modem/Phoneline Connection

Plug incoming telephone line into the “In” socket at the back of the UPS. Use on telephone line cable and plug one end of the telephone line cable to the “Out” socket at the back of the UPS. Plug the other end to the modem input socket.

6. DC Start Function

DC Start Function enables UPS to be started up when AC utility power is not available and battery is full charged. Just simply press the On/Off switch to turn on the UPS.

4. INSTALLATION

7. Turn On/Off

To turn on/off the UPS, you should press the on/off switch three seconds at least.

8. UPS Setup

All models series are designed for tower and rack purpose. They can be installed as a 19 inch equipment rack, and 3000VA can be placed in a tower (with optional stand) as well. Please follow the instruction for Tower Setup or Rack-Mount Setup.

9. Tower Setup

This series can be placed in horizontally and vertically. 3000VA model is designed in a rack itself. As a tower, it is provided with the optional UPS stand to stabilize the UPS when the UPS is positioned in vertically. The UPS stand must be attached to the bottom of the tower.

- **Tower form**

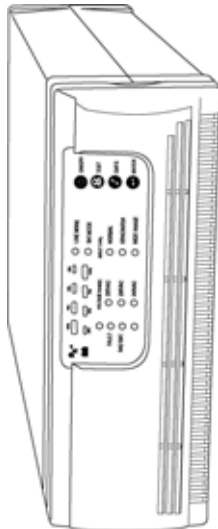

4. INSTALLATION

HV 3000VA

- **Tower form setup**

1. Slide down the UPS vertically and put two UPS stands at the end of the tower.

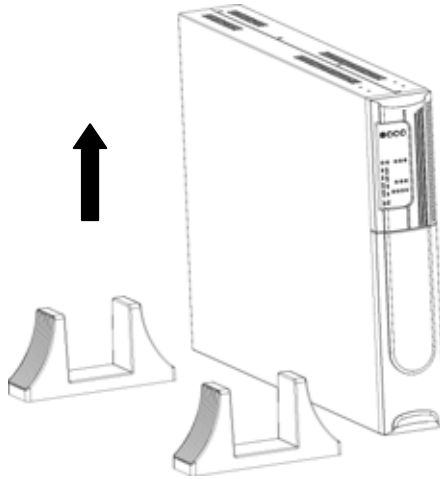

2. Place the UPS into two stands carefully.



4. INSTALLATION

- EBM and EBM integrate a rack form

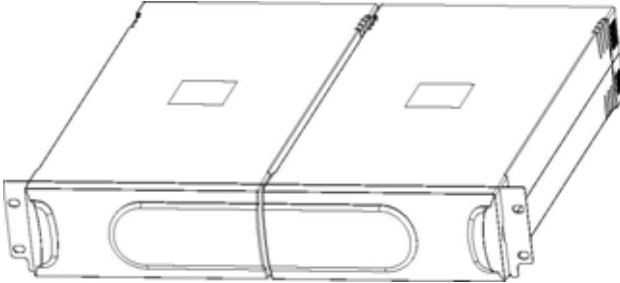

HV 3000VA

Install the 3000VA series into 19" rack as shown below.



9. Turn on the UPS and connect the load.
10. After installing the UPS into rack, the load may be connected. Make sure the load equipment is turned off, then plug all loads into the output receptacle properly protected by a circuit breaker or fuse in accordance with national and local electrical codes.

4. INSTALLATION

10. Emergency Power Off(EPO) set up

HV 3000VA include EPO port that allows power to be shut down the protected equipment immediately and does not follow the shutdown procedure from any power management software.

Note: When EPO switch is reset, the equipment will not return to battery power until the UPS is manually restarted. If pressing power switch to turn off UPS after EPO is activated, the UPS remains in Standby mode when restarted until pressing power switch to turn on the UPS again.

Follow the procedure to install the EPO switch as below.

1. Check the UPS is turned off.
2. Remove the EPO connector from the EPO port on the rear panel of UPS
3. Connect isolated, normally-open, dry contacts (rated to handle 60Vdc maximum, 30Vac RMS maximum, and 20mA maximum) across the EPO device to Pin 1 and Pin 2. Use non-shield wiring, size 18-22 AWG (0.75 mm² – 0.3 mm²).
4. Reconnect the EPO connector to the EPO port.
5. Verify that the externally-connected EPO switch is not activated to enable power to the UPS output receptacles.
6. Plug in the UPS, then pressing power switch  button to turn on the UPS.
7. Activate the external EPO switch to test the EPO function
8. De-activate the external EPO switch and restart the UPS.

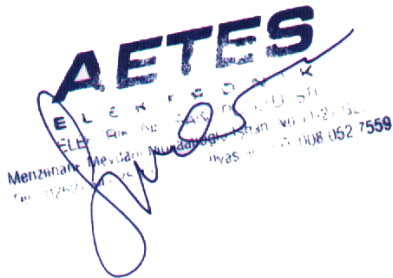

5. BATTERY REPLACEMENT

When the Bad Battery ^{BAD BAT.}  indicator flashes and there is a continuous sounding, the battery may need to be replaced. Please check the battery connection or contact your local dealer to order new battery.

CAUTION: A battery can present a risk of electrical shock and high short circuit current. The following precautions should be observed before replacing the batteries.

1. Turn off the UPS and disconnect the utility power cord from the wall outlet.
2. Remove rings, watches, and other metal objects.
3. If the battery replacement kit is damaged in anyway or shows signs of leakage, contact your dealer immediately.
Properly recycle or dispose of used battery. Do not dispose of batteries in a fire. The batteries may explode.

Note: If you are not qualified service personnel to replace the battery, do not attempt to open the battery door. Please call local dealer or distributor immediately.

Recycle the used battery:

- Never dispose the batteries in a fire. It may explode.
- Do not open or mutilate the batteries. Released electrolyte is harmful to the skins and eyes. It may be toxic. A battery can present a risk of electrical shock and high short circuit current.

To recycle properly the used battery, please do not discard the UPS, battery pack, and batteries into the trash bin. Please follow your local laws and regulations; you may contact your local recycling waste center for further information to dispose properly of the used UPS, battery pack, and batteries.

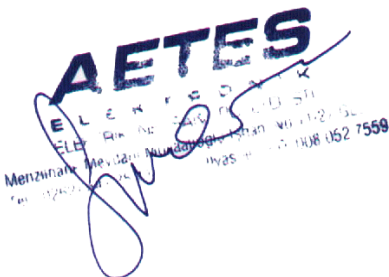

1. Unscrew the battery bracket from the EBM



2. Remove the battery bracket from EBM by pulling on both ends.

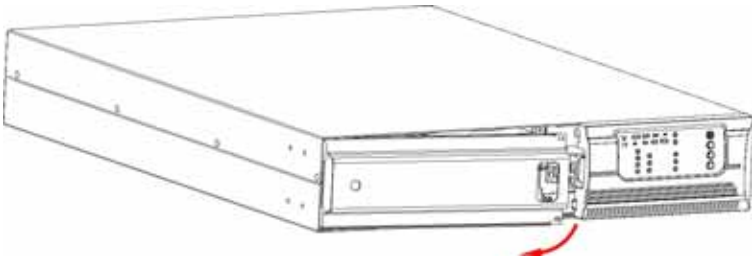

3. Pull the battery out (from right side) onto flat area.

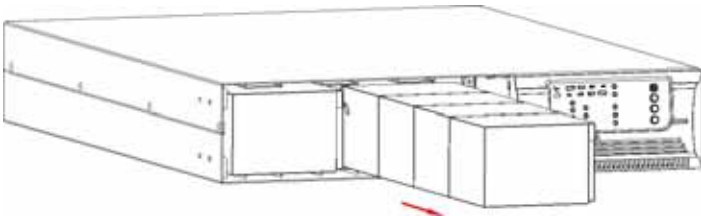

4. Pull the left side of battery out onto flat area.

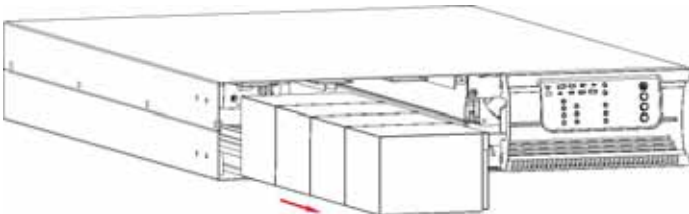

5. Slide the new batteries into EBM.
6. Reconnect the battery cable and screw up the battery bracket.
7. Close and reinstall the front panel back to EBM.

6. COMMUNICATION PORT

7.1 RS232 + Dry contact (HV 3000VA):

DB9 Female (RS232 +dry contact)

PIN #	Description	I/O	Function Explanation
1	DCD	Output	Low Battery Output (*normally open, pull to Pin#5 when battery low alarm in battery mode)
2	RxD	Output	RxD
3	TxD	Input	TxD
4	DTR	Input	(tied to pin 6)
5	Common	--	Common (tied to chassis)
6	DSR	Output	(tied to pin 4)
7	RTS	Input	No connection
8	CTS	Output	AC Fail Output (*normally open, pull to Pin#5 when UPS is in battery mode).

7.2 USB port: HID protocol

The USB and RS232 are unable to operate at the same time. Either only USB or DB9 can connect with RS-232 at one time, usually connecting with USB function is priority.

7. TROUBLE SHOOTING

Audible Alarm Trouble Shooting:

Problem	Cause	Solution
Sounding every 4 seconds	The UPS is on battery	Check the input voltage
Sounding every second	The battery is running low	Save your work and turn off your equipment
Continuously sounding	The UPS fails	Please contact your local dealer
Sounding every second	Output overload	Check load level indicator and remove some load
Continuously sounding	Battery may need to charge or service	Replace the battery

General Trouble Shooting:

Problem	Cause	Solution
The UPS is not on when power switch is pressed	The power cord is not connected correctly	Check the power cord connection
	The wall outlet may be faulty	Please contact your local qualified electrician
	The UPS output may short-circuit or overload	1. Disconnect all loads and ensure nothing is lodged in output receptacles 2. Ensure loads are not defective or shorted internally
	Internal fuse may be blown	Please contact your local dealer
UPS could not provide power to the load	Power presents on one output receptacle	Check the output fuse
	No output from any output receptacle	1. Check the connected cable 2. Ensure the load does not exceed the maximum rating of UPS
Battery has reduced backup time	Battery is not charged	Re-charge the battery at least 24 hours

Trouble Shooting Guide (Continue)		
Problem	Cause	Solution
.	Battery may not able to hold a full charge due to age.	1. Recharge the battery at least 8 hours 2. Replace Battery
The UPS fault LED lights on	The UPS fails	Save your work and turn off equipment. Please contact your local dealer
Connected equipment's lose power while connected to the UPS	The UPS may be over- loaded	Check the load status
	The UPS may be failed	Please contact your local dealer
The UPS is beeping continuously	The UPS is in fault condition	Check the audible alarms condition table
Buttons does not work	1. The UPS is in green mode 2. Button is Broken	1. Wait for a while and try again 2. Please contact your local dealer

AETES
E L E K T R I K
ELEKTRIKAL
Menzina
1008 052 7559

8. SOFTWARE INSTALLATION

WinPower is a brand new UPS monitoring software, which provides user-friendly interface to monitor and control your UPS. This unique software provides safely auto shutdown for multi-computer systems while power failure. With this software, users can monitor and control any UPS on the same LAN no matter how far from the UPSs.

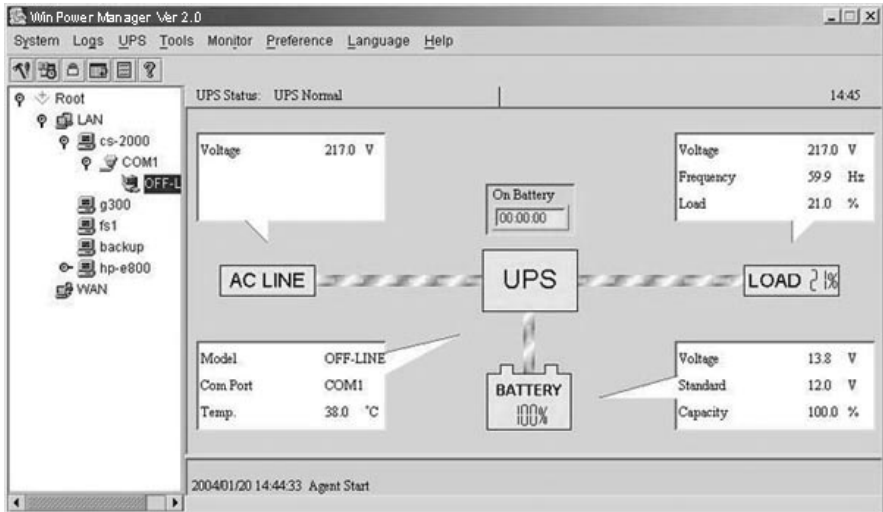

Installation procedure:

1. Go to the website:
http://www.aetes.com/download/Winpower_setup_Windows.exe
2. Choose the operation system you need and follow the instruction described on the website to download the software.
3. When downloading all required files from the internet, enter the serial No: 511C1-01220-0100-478DF2A to install the software.

When your computer restarts, the WinPower software will appear as a green plug icon located in the system tray, near the clock.